

FUNCTIONAL MORPHOLOGY OF FEEDING IN PRIMITIVE AND DERIVED ACTINOPTERYGIANS

I. OPENING THE MOUTH

A. Hyoid Coupling (present in primitive and derived actinopterygians)

- Examine the dissected rockfish head
- Locate the following: **hypaxial musculature**, **epaxial musculature**, hyoid apparatus, **protractor hyoideus**, **sternohyoideus**, and cleithrum (see Figure 1). Note connections and orientation of these elements.
 - How are these muscles and bone structures used to move the floor of the mouth and open the mouth? Which muscles initiate this process?
 - What is the net result of downward and backward movement of the floor of the mouth prior to opening the mouth?
 - What factors determine the effectiveness of gape and suck feeding for an individual species of fish?
 - If a living rockfish sustained injuries to the oral and/or opercular membranes, how would its feeding ability be affected? How would prey retention be affected?

B. Opercular Coupling (present in derived actinopterygians)

- Examine the dissected rockfish head
- Locate the following: opercular apparatus, *levator operculi*, and the ligament that attaches the opercular apparatus to the lower jaw (see Figure 2).
 - Using the elements you have just located, in addition to the ones involved with hyoid coupling, describe how opercular coupling works.
 - What is the consequence of severing the ligaments between the opercular apparatus and the lower jaw of a living fish? Could it still open its mouth?
 - What types of fishes can use opercular coupling (derived or primitive)? What is the advantage for fishes with this ability?

II. CLOSING THE MOUTH

- Examine the dissected rockfish head.
- Locate the following and describe the function of each of these elements in mouth closure: suspensorium, **adductor mandibulae**, **primordial ligament**, and the ligamentous connection between the maxilla and dentary (see Figure 3).
- On the dissected rockfish head, look for individual components of the adductor mandibulae—don't worry about naming them.
 - Identify the consequences for a living fish that severs either the primordial ligament or the one that connects the maxilla to the dentary.

III. DENTITION

- Examine the teeth of Engraulidae (anchovy), Characidae (piranha and pacu), Salmonidae (salmon and trout), Serranidae (sea bass), Lutjanidae (snapper), and Tetraodontidae (puffers) (see Figure 4 in handout).
 - Name which bones have teeth in each specimen.
 - Compare the size and shape of the teeth in each specimen. How do they differ? Based on dentition alone, what can you say about their feeding behavior and prey types?
- Examine the premaxilla and maxilla of the preserved specimens. Locate the teeth and ascending process (if present) on these bones.
- What does the presence of absence of these structures indicate about the evolutionary status of a fish?

IV. FEEDING MODES

- Examine the preserved fishes designated for feeding mode comparisons.
 - Based on what you have learned in this course, what feeding mode do these fishes use (e.g.—hit and run, filter feeding, or gape and suck)?

The hyoid coupling of actinopterygian fishes: (Figure 1)

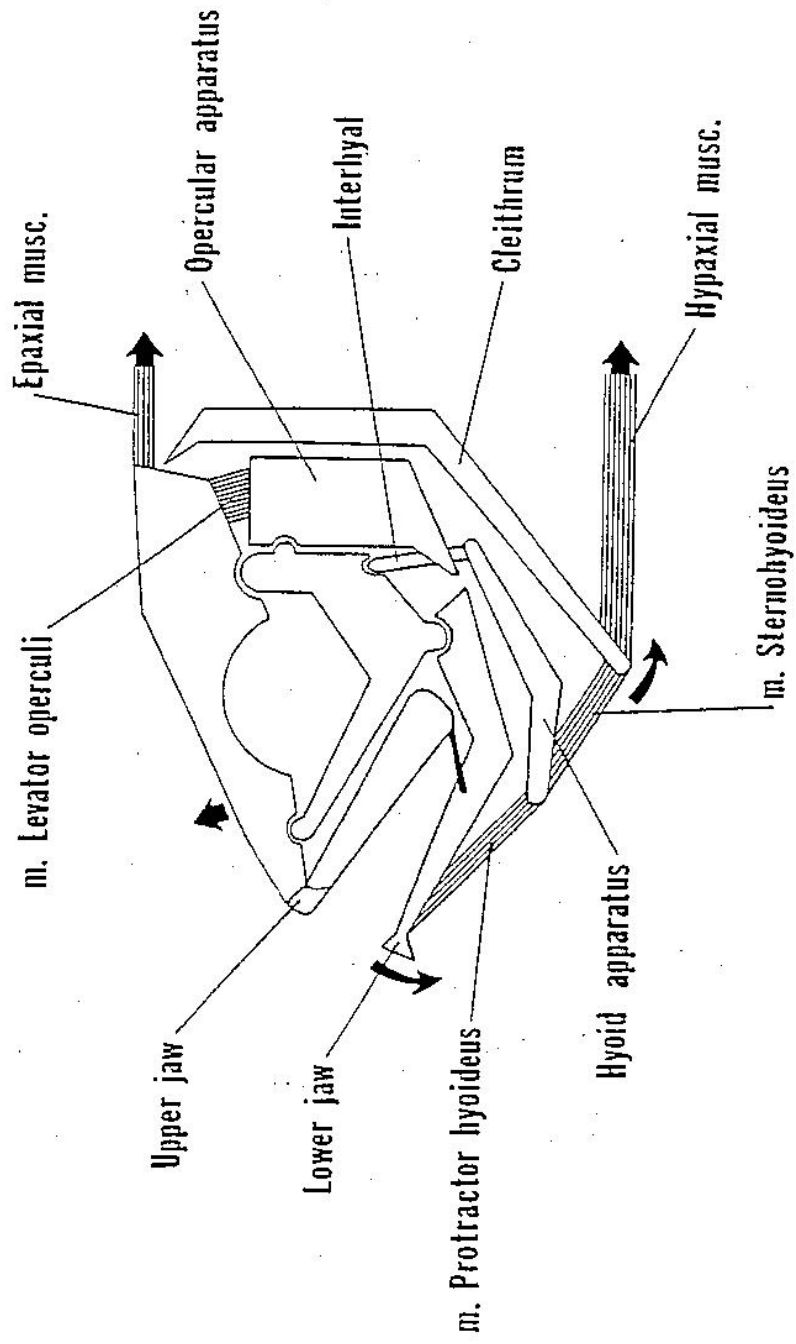

The opercular coupling of derived actinopterygians: (Fig. 2)

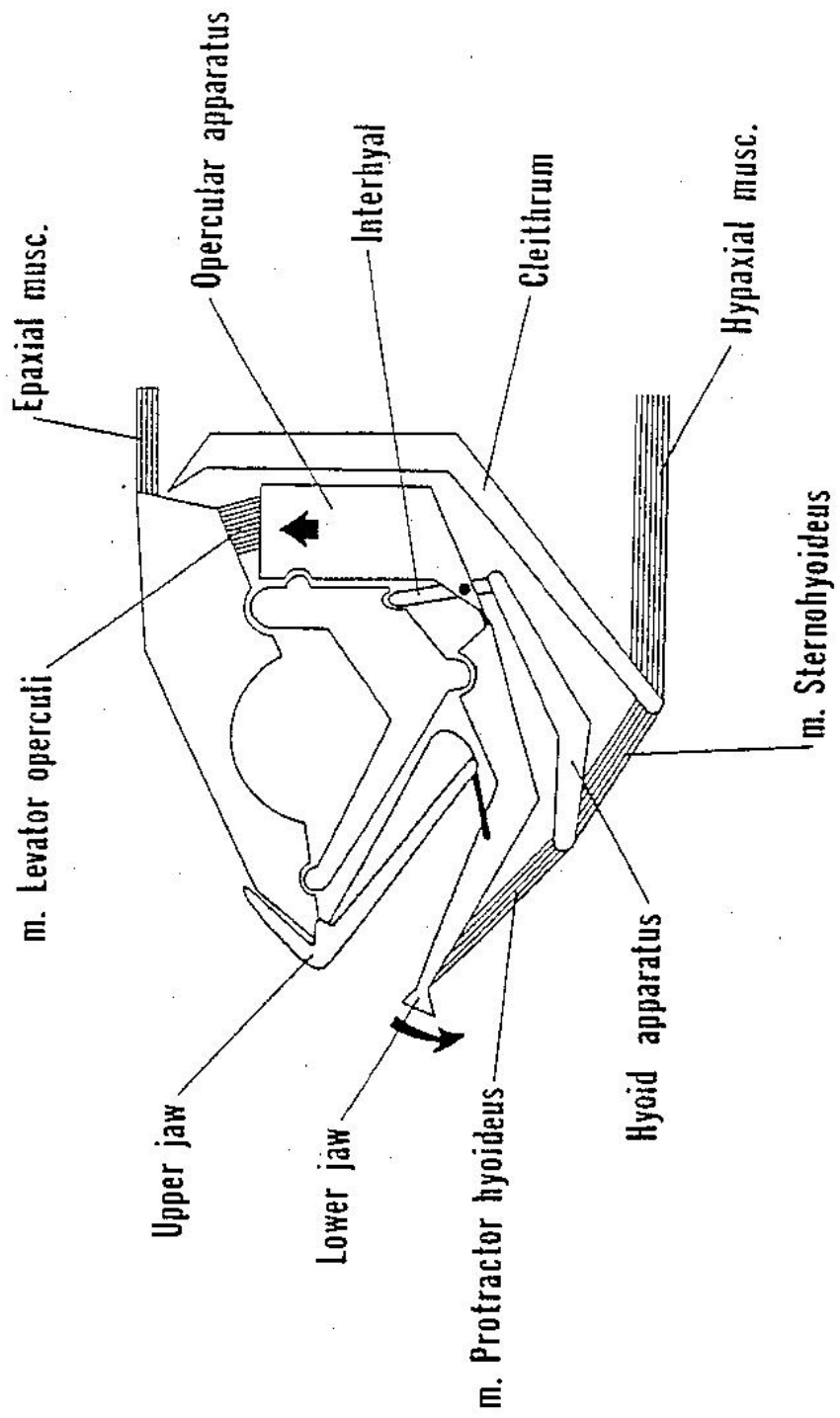

CLOSING THE MOUTH. (Fig. 3)

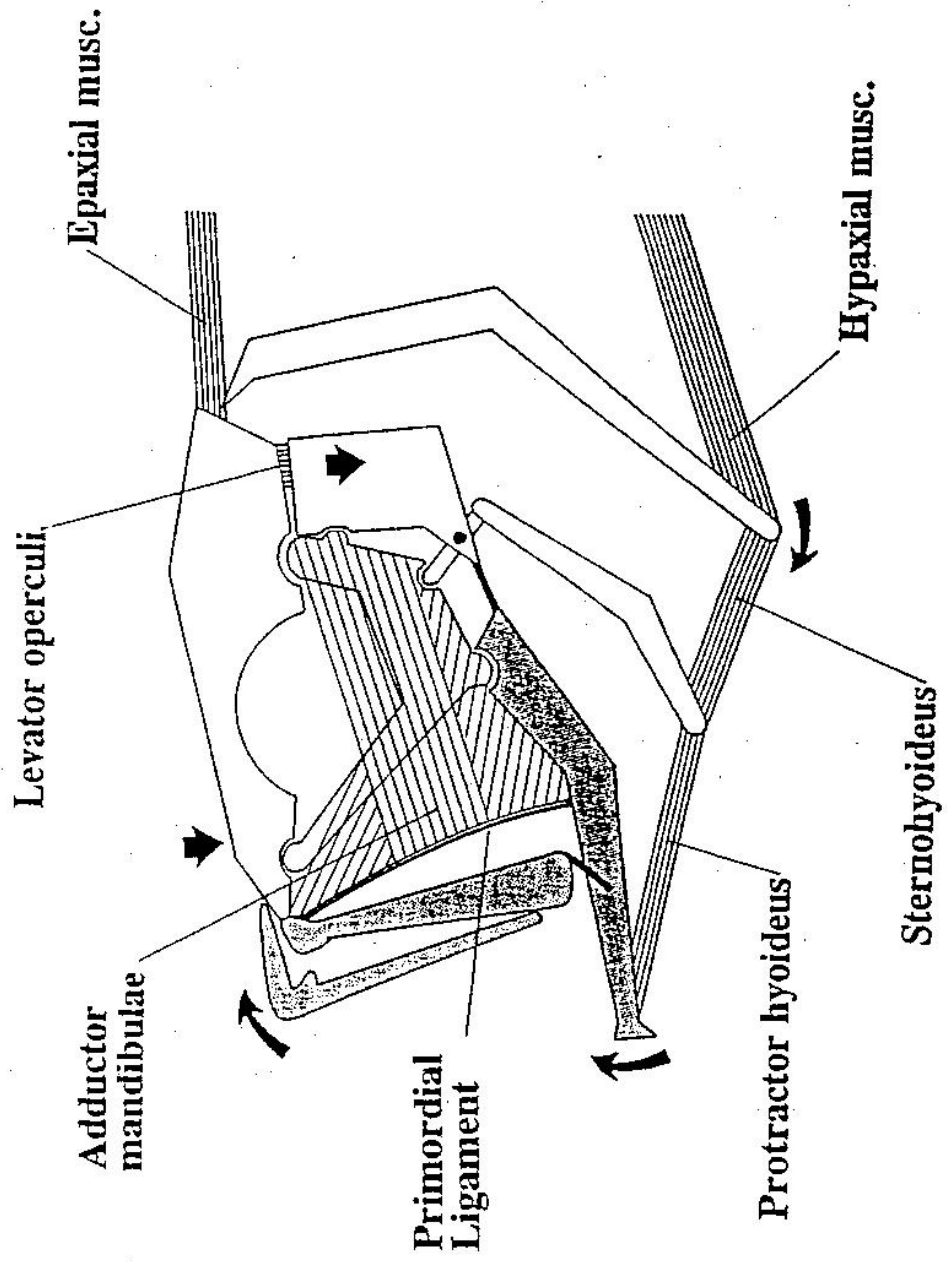

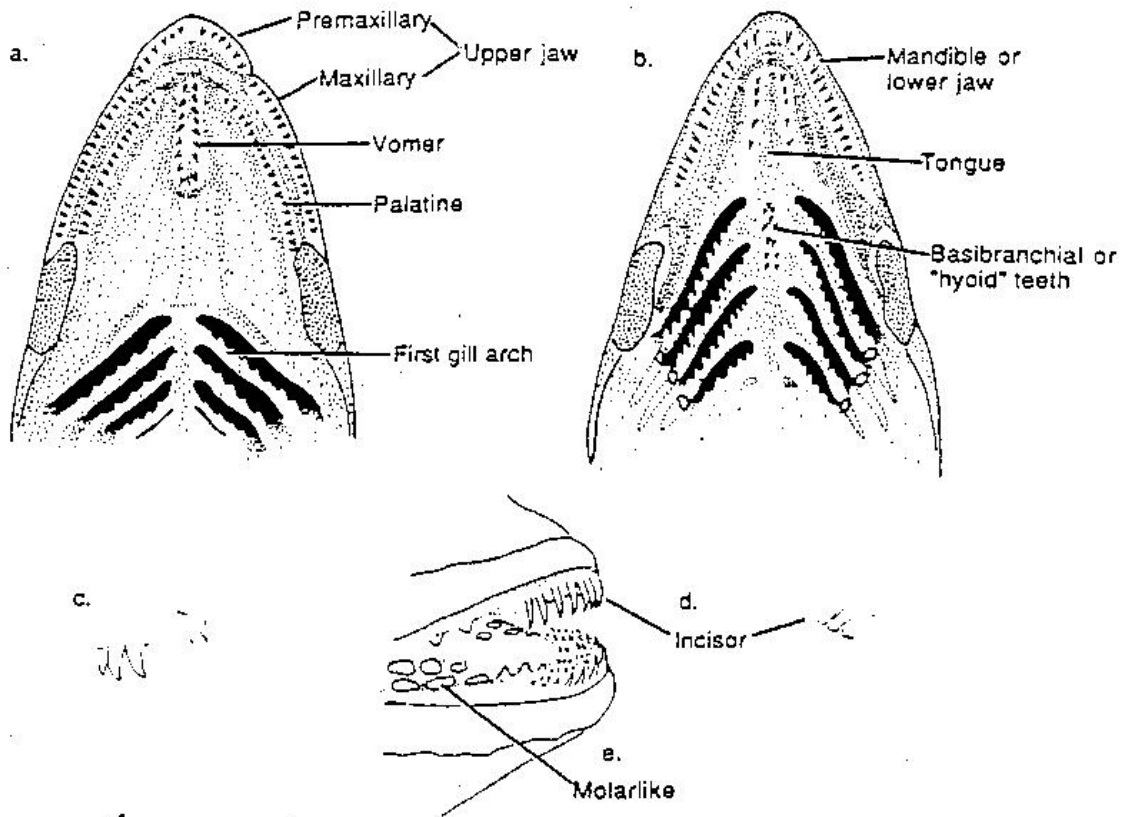

4

Figure 4 Diagram of the bones inside the mouth or buccal cavity that may bear teeth in bony fishes, with pictures of the different kinds of teeth existing in the heads of fishes: (a) the roof of the mouth showing bones with teeth; (b) the floor of the mouth showing bones with teeth and tongue; (c) caniniform teeth; (d) incisors; (e) molarlike teeth. (Miller and Lea 1972)